

2006 Harley-Davidson VRSCR Street Rod *CycleStats™*

SPECIFICATIONS AND PERFORMANCE DATA

ENGINE

Type:.....liquid-cooled, 60° V-twin
 Valvetrain:DOHC, 4 valves per cyl.,
 adjusting shims under buckets
 Size:1130cc
 Bore/stroke:100.0mm x 72.0mm
 Comp. ratio:11.3:1
 Carburetion: Delphi sequential port EFI
 53mm throttle bodies x 2
 Exhaust:2-1-2

DRIVE TRAIN

Transmission:5-speed
 Final drive:Toothed belt
 RPM @ 65 mph/redline4200/9000
 (* actual, not indicated)

DIMENSIONS

Wheelbase:66.8"
 Rake/trail:30.0°(forks at 32°)/4.3"
 Ground clearance:5.25"
 Seat height:26.75"
 GVWR:1060 lbs.
 Wet weight:636 lbs.
 Carrying capacity:424 lbs.

SUSPENSION

Front: 43mm inverted cartridge forks,
 non-adjustable,
 5.0" travel
 Rear: twin telescopic, coil-over shocks,
 preload adjustable, 5.0" travel

BRAKES

Front:dual 300mm x 5.0mm discs,
 four-piston, double-action calipers
 Rear:single 300mm x 7.0mm disc,
 four-piston, double-action caliper

TIRES & WHEELS

Front:120/70ZR19 Dunlop D207
 on 3.00" x 19" 10-spoke wheel
 Rear:180/55ZR18 Dunlop D207
 on 5.50" x 18" 10-spoke wheel

ELECTRICS

Battery:12V, 12AH
 Ignition: integrated, digitally-mapped
 with throttle position sensor
 Headlight:55/65W reflector optics

FUEL

Tank capacity:5.0 gal.
 High/low/avg. mpg:33.3/37.0/35.7



PERFORMANCE

Measured top speed133.7 mph
 0-1/4 mile12.07 sec.
 @ 114.81 mph
 0-60 mph4.25 sec.
 0-100 mph9.57 sec.
 60-0 mph127.9'
 Power to Weight Ratio1:6.22
 Speed @ 65 mph indicated62.3

M/C RATING SYSTEM

EXCELLENT
 VERY GOOD
 GOOD
 FAIR
 POOR

Open Standard

Engine	●●●●○
Transmission	●●●●○
Suspension	●●●●○
Brakes	●●●●○
Handling	●●●●○
Styling	●●●●○
Riding Impression	●●●●○
Instruments/Controls	●●●●○
Attention to Detail	●●●●○
Value	●●●●○
OVERALL RATING	●●●●○

ERGONOMICS TEMPLATE

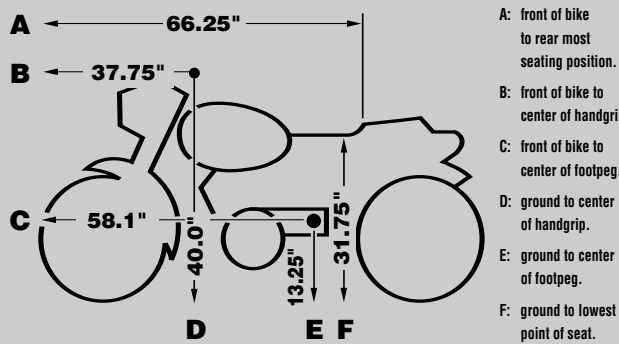

MISCELLANEOUS

Instruments: speedo, tach, fuel gauge,
 multi-function LED odometer/
 tripmeter/distance to empty
 Indicators: hi-beam, t/s, neutral,
 oil pressure, coolant temp., low fuel,
 engine diagnostics
 MSRP:\$16,495
 Valve adj. interval:15,000 mi.
 (after initial 1000-mi. service)
 Warranty:24 mo., unlimited miles.
 Colors:Vivid Black, Black Cherry,
 Rich Sunglo Blue, Mirage Orange,
 Yellow Pearl

DYNAMOMETER DATA

Low end ●●●●○
 Mid-range ●●●●○
 Top end ●●●●○

The "Revolution" engine is counterbalanced, so it's very smooth-running. Near flawless fuel injection gives instant throttle response with minimal driveline lash, and torque is abundant from 3000 rpm for awesome passing power—great fun to ride.

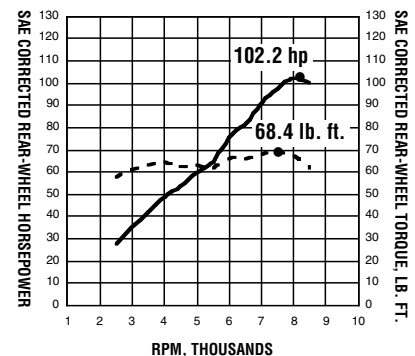

TEST NOTES

PICKS

- The sportiest production Harley ever, the real Sportster
- An exquisite engine despite the mystery power loss
- Spoked wheels no longer steer for you in crosswinds

PANS

- The rear brake pedal needs to be adjustable
- The mirrors are nearly useless, buy bar-end types
- The rider's seat is good for 50 miles between breaks

STANDARD MAINTENANCE

Item	Time	Parts	Labor
Oil & Filter	0.25	\$8.60 + \$14	\$13.50
Air Filter	0.15	\$39.95	\$8.10
Valve Adjust	4.0		\$216.00
Battery Access	0.25	MF	\$13.50
Final Drive	0.25		\$13.50
R/R Rear Whl.	0.5		\$27.00
Change Plugs	0.8	\$5.00	\$43.20
Adjust EFI (non-adjustable)			
Totals	6.2	\$67.55	\$334.80