

2005 MZ1000S

SPECIFICATIONS AND PERFORMANCE DATA



ENGINE

Type:Liquid-cooled, 4-stroke parallel twin
 Valvetrain: DOHC, four-valve, variable thickness bucket valve adjustment
 Size:998cc
 Bore/stroke:96.0mm x 69.0mm
 Comp. ratio:11.5:1±0.5:1
 Fueling:Sagem EFI
 46mm throttle bodies
 Exhaust:2-2 w/crossover

DRIVE TRAIN

Transmission:6-speed
 Final drive:#530 chain
 RPM* @ 65 mph/redline ..4380/9400
 (*actual, not indicated)

DIMENSIONS

Wheelbase:56.1"
 Rake/trail.....24°/4.06"
 Ground clearance:5.5"
 Seat height :32.5"
 GVWR:939 lbs.
 Wet weight:514.5 lbs.
 Carrying capacity:424.5 lbs.

SUSPENSION

Front:43mm inverted Marzocchi cartridge forks, with adj. preload, compression and rebound damping 4.7" travel
 Rear:Sachs monoshock with adj. compression, rebound and remote preload adjuster 4.7" travel

BRAKES

Front:Twin Nissin 4-piston, double-action calipers on twin 320mm semi-floating discs
 Rear: ..Single Nissin 243mm disc with two-piston, double-action caliper

TIRES & WHEELS

Front:120/70ZR17 Michelin Pilot Sport on 3.50" x 17" wheel
 Rear:180/55ZR17 Michelin Pilot Sport on 5.50" x 17" wheel

ELECTRICS

Battery:12V, 12AH
 Ignition:Sagem digital engine management
 Headlight:60/60W

FUEL

Tank capacity:5.3 gal.
 Grade specified95 (ROZ)
 High/low/avg. mpg:41.4/22.1/31.6



PERFORMANCE

Measured top speed146.8 mph
 0-1/4 mile10.97 sec.
 @ 119.55 mph
 0-60 mph3.03 sec.
 0-100 mph7.54 sec.
 60-0 mph116.8'
 Power to Weight Ratio1:5.05
 Speed @ 65 mph indicated56.4

M/C RATING SYSTEM

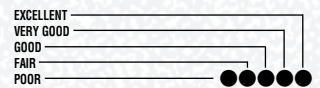

Open Sport

| | |
|-----------------------|-------|
| Engine | ●●●●● |
| Transmission | ●●●●○ |
| Suspension | ●●●●● |
| Brakes | ●●●●● |
| Handling | ●●●●● |
| Styling | ●●●●○ |
| Riding Impression | ●●●●● |
| Instruments/Controls | ●●●●○ |
| Attention to Detail | ●●●●○ |
| Value | ●●●○ |
| OVERALL RATING | ●●●●○ |

ERGONOMICS TEMPLATE

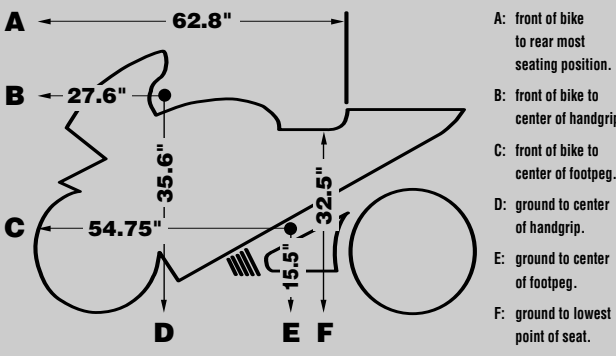

MISCELLANEOUS

Instruments: Analog speedo and tach, digital coolant temp., fuel level, clock, odometer and tripmeter
 Indicators: High beam, neutral, turnsignals, emergency flashers, check engine light
 MSRP:\$10,995
 Routine service interval:.....6000 mi.
 Valve adj. interval:12,000 mi.
 Warranty:2 yrs., unlimited miles.
 Colors:Black, Silver

DYNAMOMETER DATA

Low end ●●●●○
 Mid-range ●●●●○
 Top end ●●●●○

The MZ's Sagem engine management works very well, giving smooth response and tractable power all the way to redline, together with useful compression braking off throttle. Counterbalanced, it smooths out nicely above 4000 rpm.

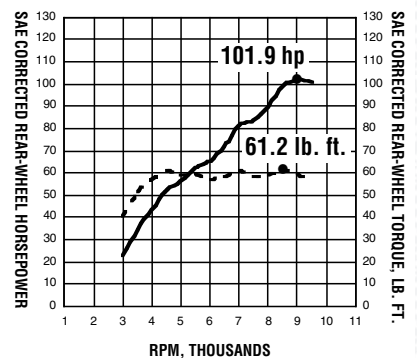

TEST NOTES

PICKS

- Superbly well-balanced handling
- Powerful, linear and very controllable brakes
- Distinctive styling with a comfortable riding position

PANS

- Mirrors aren't wide enough and blur images badly
- Terribly inaccurate speedo makes judging speed a chore
- Clutch shudder hurt our quarter-mile performance tests

STANDARD MAINTENANCE

| Item | Time | Parts | Labor |
|----------------|-------------|-----------------|-----------------|
| Oil & Filter | 0.7 | \$19.95 + \$20 | \$42.00 |
| Air Filter | 0.2 | \$49.95 | \$12.00 |
| Valve Adjust | 1.5 | \$139.80 | \$90.00 |
| Battery Access | 0.15 | MF | \$9.00 |
| Final Drive | 0.15 | | \$9.00 |
| R/R Rear Whl. | 0.6 | | \$36.00 |
| Change Plugs | 0.25 | \$21.90 | \$15.00 |
| Synch EFI | 0.5 | | \$30.00 |
| Totals | 4.05 | \$251.60 | \$243.00 |

Note: MCN Labor rate changed to \$60/hr. from \$54/hr. in May 2002